



Technical specifications and instructions



35 Frame Plunger Pumps

Forged brass 3545HS
Stainless steel 3541DHS
SS flushed 3541CHS

Specifications (*)

Model 3545HS-3541D-3541CHS

Flow	189 L/min
Pressure range	6,9 to 103 bar
RPM	850 RPM
Inlet pressure range	Flooded to 4.8 bar
Stroke	48 mm

Common specifications

Bore	45 mm
Crankcase capacity	4 L
Maximum liquid temperature	60° C
Inlet ports (2)	1-1/2" NPTF
Flushing ports (2)	1/4" NPTF
Discharge ports (2)	1 NPTF
Shaft diameter	35 mm
Weight	63 kg
Dimensions	606 x 460 x 247 mm

(*) Abnormalities permitted only after consultation and written confirmation from Cat Pumps.

Exploded View

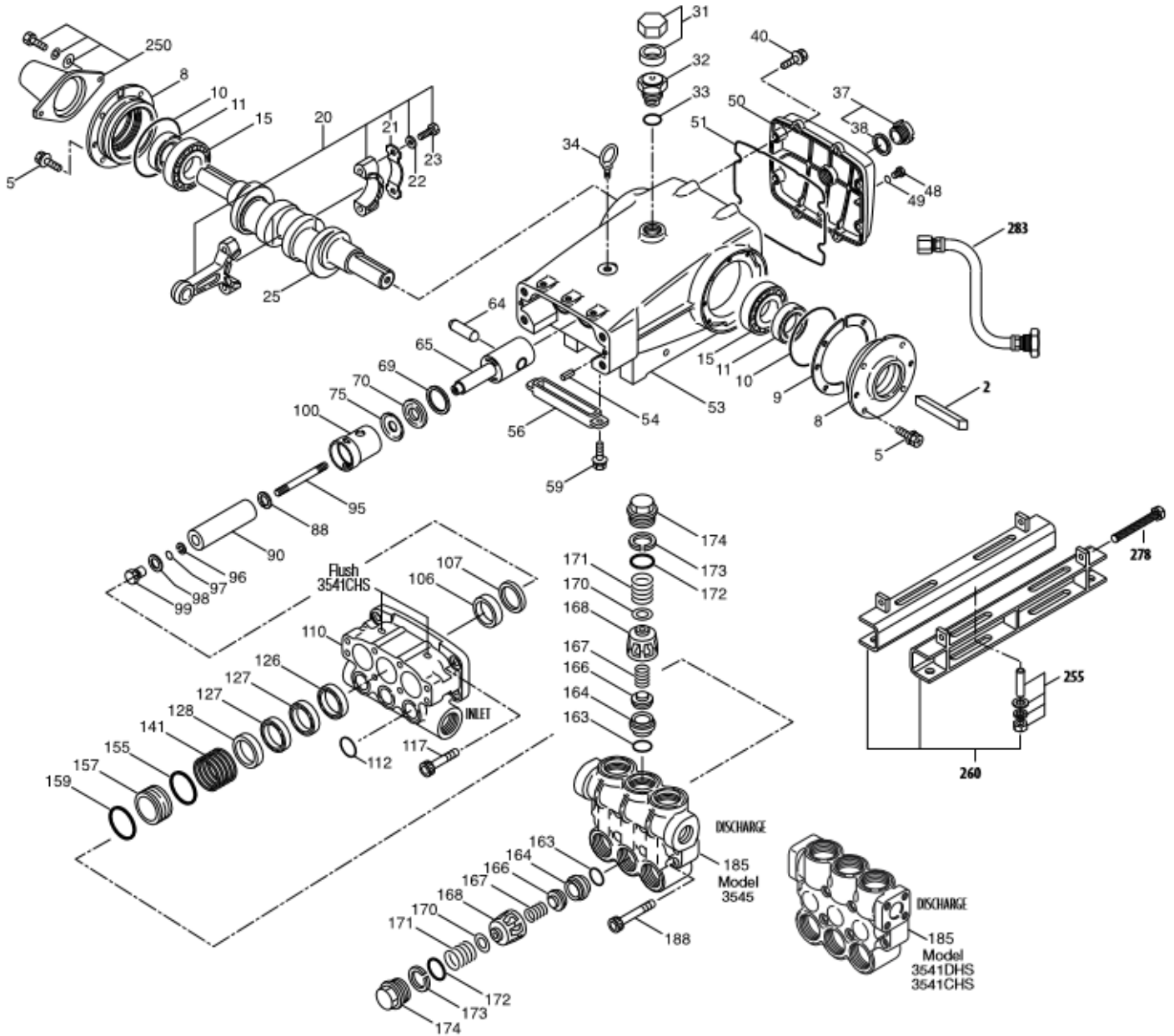

Model
 Brass - 3545HS
 Stainless Steel - 3541CHS, 3541DHS
 October 2018

Parts list

Item	Num. 3545HS	Mat.	Num. 3541DHS 3541CHS	Mat.	Description	Qty
2	34021	STL	34021	STL	Key (M10x8x70)	1
5	96049	S	96049	S	Screw, HH sems (M10x25) (see TB 125) {06/18}	8
8	134604	ALE	134604	ALE	Cover, bearing (see TB 118,125) {06/18}	2
9	815279	FBR	815279	FBR	Shim, split 2-pc (see TB 125) {06/18}	4
10	12398	NBR	12398	NBR	O-ring, bearing cover – 70D	2
11	13296	NBR	13296	NBR	Seal, oil, crankshaft	2
15	29326	STL	29326	STL	Bearing, roller	2
20	126725	BZ	126725	BZ	Rod, connecting assy (incl. 21,22,23)	3
21	126749	STCP R	126749	STCP R	Washer, locking (M10)	6
22	126593	STCP R	126593	STCP R	Washer, flat (M10)	6
23	122045	STZP	122045	STZP	Screw, HH (M10x55)	3
25	29325	FCM	29325	FCM	Crankshaft, dual end	1
31	828710	PE	828710	PE	Protector, cap w/foam gasket	1
32	43211	ABS	43211	ABS	Cap, oil filler	1
33	14177	NBR	14177	NBR	O-ring, oil filler cap – 70D	1
34	126743	STCP R	126743	STCP R	Bolt, eye (M12x1,75) (for lifting pump only)	1
37	92241	-	92241	-	Gauge, oil, bubble w/gasket	1
38	44428	NBR	44428	NBR	Gasket, flat, oil gauge – 80D	1
40	125753	S	125753	S	Screw, HHC sems (M8x25)	8
48	25625	STCP	25625	STCP	Plug, drain (1/4" x 19 BSP)	1
49	23170	NBR	23170	NBR	O-ring, drain plug – 70D	1
50	45936	AL	45936	AL	Cover, rear (see TB 118)	1
51	16612	NBR	16612	NBR	O-ring, crankcase cover – 70D	1
53	134784	AL	134784	AL	Crankcase assy (incl. 34,54) (see TB 118,125) {06/18}	1
54	27488	S	27488	S	Pin, guide	2
56	27790	POP	27790	POP	Pan, oil	1
59	92538	S	92538	S	Screw, HHC sems (M6x16)	2
64	43864	CM	43864	CM	Pin, crosshead	3
65	49166	SSHB	49166	SSHB	Rod, plunger	3
69	126587	STCP R	126587	STCP R	Washer, oil seal	3
70	100488	NBRS	100488	NBRS	Seal, oil, crankcase	3
	44739	FPM	44739	FPM	Seal, oil, crankcase	3
75	43865	S	43865	S	Slinger, barrier	3
88	45676	S	45676	S	Washer, keyhole (M16)	3
90	46806	CC	46806	CC	Plunger (M45x145)	3
95	+ 89778	SS	89778	SS	Stud, plunger retainer (M10x135)	3
96	20189	PTFE	20189	PTFE	Back-up-ring, plunger retainer	3
97	11345	NBR	11345	NBR	O-ring, plunger retainer – 70D	3
98	44085	SS	44085	SS	Gasket, retainer	3
99	+ 44084	SS	44084	SS	Retainer, plunger (M10)	3
100	44119	PPG	44119	PPG	Retainer, seal (see TB 105)	3
106	46809	NBR	48384	NBR	Seal, LPS w/S-spg	3
107	46811	BB	48380	D	Spacer, LPS	3
110	49482	BBCP R	48375	SS	Manifold, inlet	1
	-	-	49304	SS	Manifold, inlet, flushed (1/4" flush port)	1
112	18688	NBR	18688	NBR	O-ring, inlet manifold – 70D	3
117	44585	S	44585	S	Screw, HSH (M14x40)	4
126	46812	BB	48383	D	Adapter, female	3
127	46813	STGS	46813	STGS	V-packing	6
128	46814	BB	48386	SS	Adapter, male	3
141	49483	SS	49483	SS	Spring, coil, large (see TB 107)	3
155	17784	NBR	17784	NBR	O-ring, V-packing spacer – 80D	3
157	49484	BB	49506	SS	Spacer, V-packing (see TB 107)	3
159	17784	NBR	17784	NBR	O-ring, V-packing spacer – 80D	3
163	26143	NBR	26143	NBR	O-ring, seat – 80D	6
164	46822	S	48393	SS	Seat	6
166	43932	S	44108	SS	Valve	6
167	44109	SS	44109	SS	Spring, valve	6
168	44728	PVDF	44728	PVDF	Retainer, spring	6
170	44729	SS	44729	SS	Washer, spring retainer	6
171	44644	SS	44644	SS	Coil spring (70 kg), valve plug	6
172	89827	NBR	89827	NBR	O-ring, valve plug – 90D	6
173	48364	D	48364	D	Back-up-ring, valve plug	6

174	46444	FBB	49300	SSD	Plug, valve	6
185	49486	BBCP R	49302	SSD	Manifold, discharge	1
188	89981	S	89981	S	Screw, HSH (M12x70)	8
250	855042	NY	855042	NY	Protector, shaft w/2 screws, washers, lockwashers (see TB 125) {06/18}	1

Bold print part numbers are unique to a particular pump model. Italics are optional items. { } Date of latest production change.
+ Production parts are different from repair parts. R-components comply with RoHS Directive. * Review individual parts in each kit for material code identification. See Tech Bulletins 024, 036, 041, 043, 053, 074, 083, 099, 105, 107, 109, 118, and 125 for additional information.

Material codes (not part or part number)

ABS	ABS plastic	FBR	Fiber	S	304SS
AL	Aluminum	FCM	Forged chrome-moly	SFTB	Special blend PTFE black
ALE	Aluminum Epoxy	FPM	Fluorocarbon	SS	316SS
BB	Brass	NBR	Medium nitrile (Buna-N)	SSD	Duplex Stainless steel
BBCP	Brass / chrome plated	NBRs	Buna, silicone free	SSHB	316 SS/ High strength brass
BZ	Bronze	NY	Nylon	STCP	Steel / chrome plated
CC	Ceramic	PC	Polycarbonate	STGS	Special blend PTFE white silicon free
CM	Chrome-moly	PE	Polyethylene	STL	Steel
D	Acetal	POP	Polypropylene	STZP	Steel / zinc plated
EPDM	Ethylene propylene diene monomer	PPG	Glass filled polypropylene	TNM	Special high strength
F	Cast iron	PTFE	Pure polytetrafluorethylene		
FBB	Forged brass	PVDF	Polyvinylidene fluoride		

OPTIONAL PARTS & ACCESSORIES

PART	DESCRIPTION	QTY
33234	Kit, seal (3545HS) – standard	1
33834	Kit, seal (3541DHS, 3541CHS) – standard	1
33235	Kit, valve (3545HS) – standard	2
33835	Kit, valve (3541DHS,3541CHS) – standard	2
92674	Mount, rail assembly	1
34018	Mount, direct (STZP R)	1
34039	Mount, direct (S)	1
990013	Hub, "B", 35 mm (STL)	1
80540	Screwing, adjusting M12 x 100	1
34314	Kit, oil drain	1
30696	Plier, reverse (not shown)	1

SERVICE PARTS

PART	DESCRIPTION	QTY
34021	Key, M10 x 8 x 70	1
818428	Head, compl. w/NBR seals & O-rings – mod. 3545HS	1
818371	Head, compl. w/NBR seals & O-rings – mod. 3541DHS	1
819000	Assy, crankcase, cast iron conversion	1

SEAL KITS - 1 seal kit required per pump

Pump model	NBR standard)	FPM (0.0110)	EPDM (0.0220) #		
3545HS	33234*	31261	33233*		
3541DHS,3541CHS	33834*	31261	33223*		
Items incl.				Description	Qty
97	11345	11375	701490	O-ring, plunger retainer	3
106	46809	48384	46945	Seal, LPS w/SS-spg	3
112	18688	11739	701659	O-ring, Inlet Manifold	3
127	46813	46813	46813	V-packing	6
155	17784	20138	701658	Back-up-ring, V-packing cylinder	3
159	17784	20138	701658	O-ring, V-packing Cylinder	3

Silicone/oil/grease required * Review material codes for individual items (STG generally may be used as alternative)

VALVE KITS - : 2 valve kits required per pump

Pump model	NBR (standard)	FPM (0.0110)	EPDM 0.0220) #		
3545HS	33235	31262	31235		
3541DHS,3541CHS	33835	31262	31264		
Items incl.				Description	Qty
163	26143	14331	701660	O-ring, valve seat	3
164	46822			Seat (3545HS)	3
		48393	48393	Seat (3541DHS,3541CHS)	3
166	43932			Valve (3545HS)	3
		44108	44108	Valve (3541DHS,3541CHS)	3
167	44109	44109	44109	Spring	3
168	44728	44728	44728	Retainer, spring	3
170	44729	44729	44729	Washer, spring retainer	3
172	89827	11747	701494	O-ring, Valve plug	3
173	48364	48364	48364	Back-up-ring, Valve plug	3

Silicone/oil/grease required